

Partner With Bison® To...

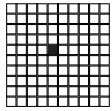

Differentiate

... your bus, truck, off-road and rail equipment using the highest quality motors and pumps that provide heavy-duty, yet light weight and compact designs, CAN functionality, long life and much more.

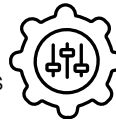

Customize

... your vehicles' air- and other fluid-moving solutions, working side by side Bison® engineers who know the dynamics of fluid and have hundreds of years of cumulative experience.



Save Time

... by running performance tests and rapid prototyping and more through a Bison® state-of-the-art engineering laboratory.



Gain Access

... to heavy-duty transportation pumps and motors that are Buy America Compliant.

Differentiate Your End Products With ROTRON® Pumps and Motors

- Brushless sealless pumps
- Brushless DC motors
- SAE J1939 CAN functionality
- Long life up to 60,000 hours
- Maintenance-free design



Bison® also manufactures a full line of brushless DC fans and impeller style blowers.

Our Engineers Can Customize Your Air- and Other Fluid-Moving Solutions to...

- Heat and cool interiors
- Cool electronics, batteries & drive motors
- De-ice entryways
- Defrost windows
- And so much more!



LEARN
MORE

Helping
Fleet
Owners....



Reduce
Operational Costs



Eliminate
Downtime



Increase
Service Time,
Revenues & Profits

47 Frame

Sealless Pump with Brushless DC Motor 60,000 Hour Design Life/18 Gallon

ROTRON®
Transportation

Pump

- Sealless design is leak proof; pump is magnetically coupled to the motor
- Motor is removable from pump without draining system
- Environmentally resistant to hot-water spray, salt, fog, shock and vibration
- Cast brass pump designed for heavy-duty applications

Motor

- 12 and 24 VDC models available
- Electronically Commutated DC (ECDC™) motor design provides for maintenance-free operation by eliminating brush motor failures and brush maintenance
- Rare-earth magnets provide high efficiency and low current draw
- “O” ring sealed for harsh operating environment



- Reverse polarity and surge protected
- Heavy-duty construction required for transit bus and construction equipment
- Available with or without baseplate and connectors

Performance

12 Volt

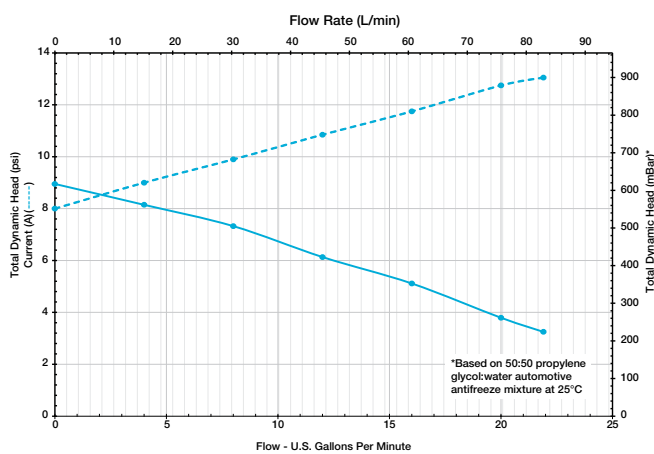

24 Volt

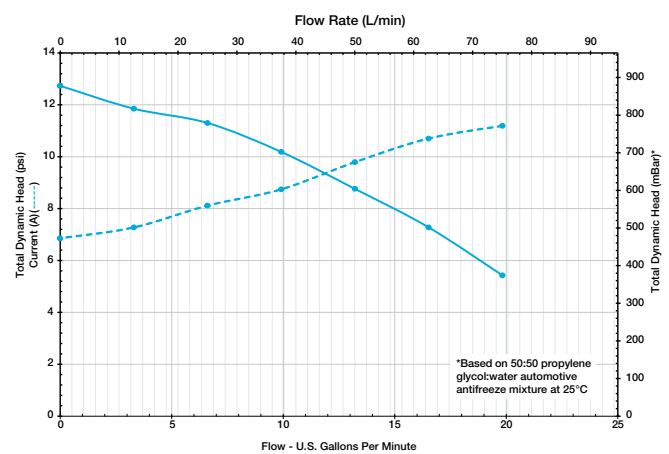

LEARN
MORE

47 Frame



Sealless Pump with Brushless DC Motor 60,000 Hour Design Life/18 Gallon

ROTRON®
Transportation

Typical Dimensions

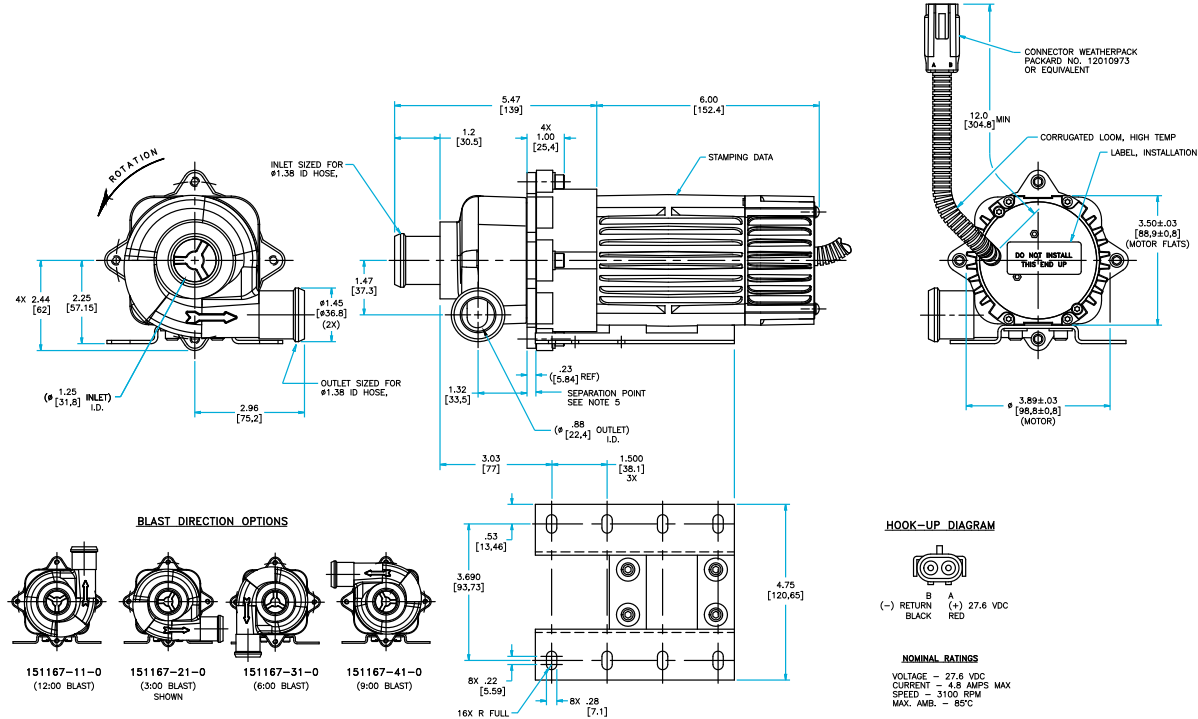
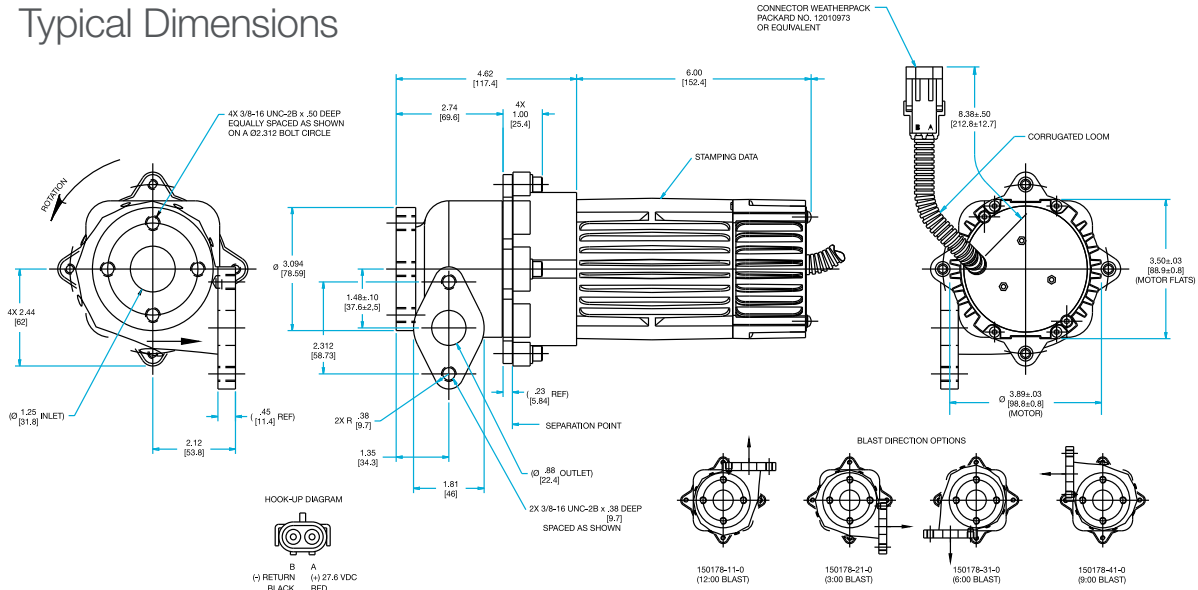

- Motor design characteristics are based on an operating environment of 85°C.
- Approximate typical weight: 15.0 lbs.



LEARN MORE

This document is for informational purposes only and should not be considered as a binding description of the products or their performance in all applications. Actual performance will vary depending on the operating environment and application.

Sealless Pump with Brushless DC Motor 60,000 Hour Design Life/26 Gallon

ROTRON®
Transportation

Pump

- Sealless design is leak proof; pump is magnetically coupled to motor
- Motor is removable from pump without draining system
- Environmentally resistant to hot-water spray, salt, fog, shock, and vibration
- Cast brass pump designed for heavy-duty applications

Motor

- 24 VDC model only
- Motor design provides for maintenance-free operation by eliminating brush motor failures and brush maintenance
- Rare-earth magnets provide high efficiency and low current draw
- "O" ring sealed for harsh operating environment
- Reverse polarity and surge protected
- Heavy-duty construction required for transit bus and construction equipment



Performance

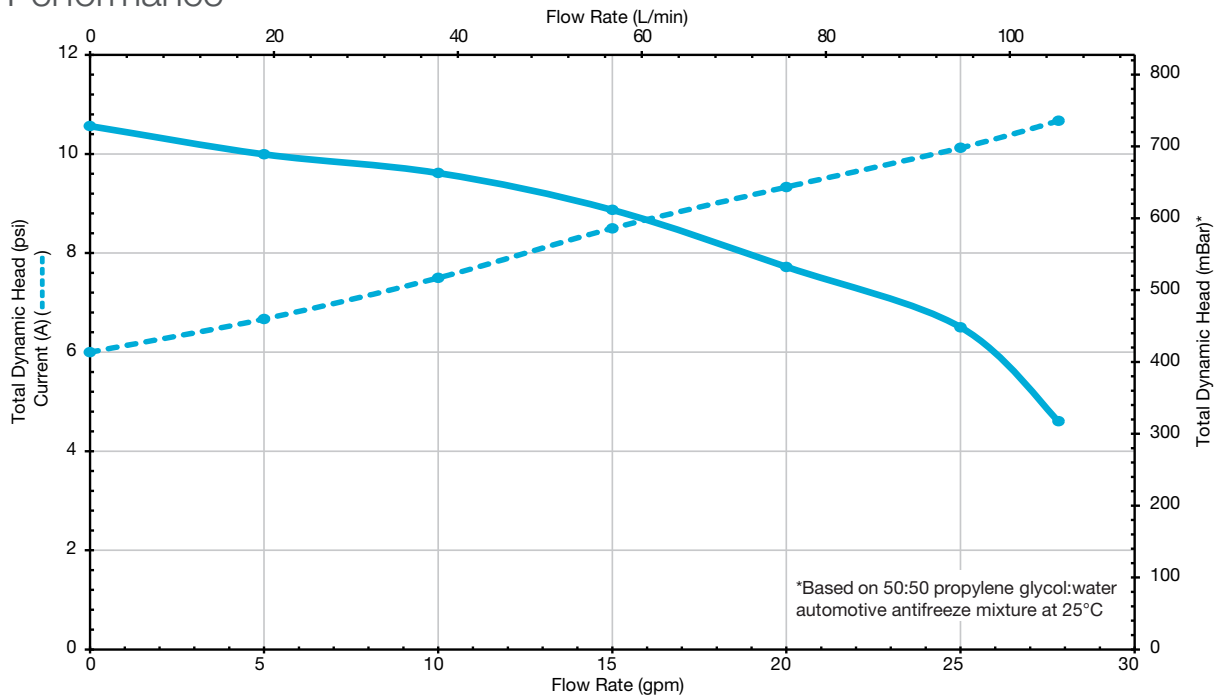

100

About **Bison®**

For more than 100 years, Bison® has helped customers differentiate their products by developing robust, flexible and durable motors, blowers and pumps under the brand names - Bison® Gearmotors, Lamb®, Nautilair®, Prestolite Motors, ROTRON® Regenerative Blowers, ROTRON® Transportation and Windjammer®.

Bison® engineers thrive on technical challenges and provide customers collaborative, customizable and optimized fluid-moving, fractional and integral horsepower solutions. Bison® has worldwide sales representative support, research facilities and manufacturing facilities in the United States, China and Mexico. The company is headquartered in Kent, Ohio.

Bison® is a business of AMETEK, Inc. — a leading global provider of industrial technology solutions serving a diverse set of attractive niche markets with annual sales over \$6.0 billion.

75

About **ROTRON® Transportation Pumps and Motors**

For more than 75 years, Bison® has designed and manufactured **ROTRON®** brushless sealless pumps and brushless DC motors for heavy-duty transportation OEMs building trucks, buses, locomotives, light rail equipment, off-road vehicles and more.

Our ROTRON® transportation products offer long life up to 60,000 hours, CAN J1939 functionality and maintenance-free designs. The fluid-moving technologies can be customized to OEM specs and are **Buy America Compliant**.