

LAMB ELECTRIC

Model: 116137-00

DESCRIPTION

- Three stage
- 120 volts
- 7.2"/183 mm diameter
- Double ball bearings
- Single speed
- Peripheral bypass discharge
- Aluminum fan end bracket
- Aluminum commutator bracket

DESIGN APPLICATION

- Equipment operating in environments requiring separation of working air from motor ventilating air
- Designed to handle clean, dry, filtered air only

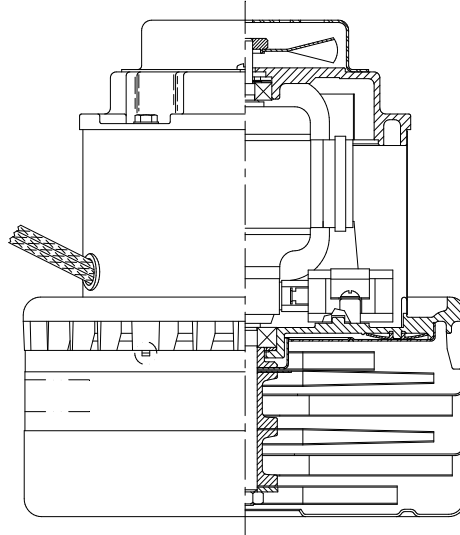

SPECIAL FEATURES

- Suitable for 120 volt AC operation, 50/60 Hz
- UL recognized, category PRGY2 (E47185)
- CSA certified, class 1611 01 (LR31393)
- Provision for grounding
- The Lamb Electric vacuum motor line offers a wide range of performance levels to meet design needs

TYPICAL MOTOR PERFORMANCE.*

(At 120 volts, 60Hz, test data is corrected to standard conditions of 29.92 Hg, 68° F.)

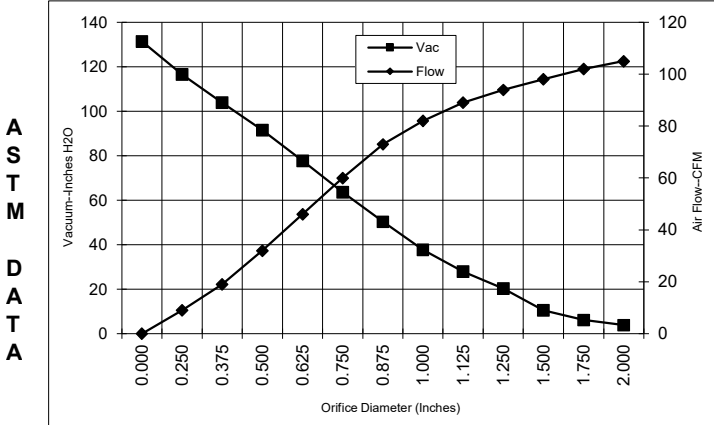

Orifice (Inches)	Amps	Watts (In)	RPM	Vac (In.H ₂ O)	Flow (CFM)	Air Watts
2.000	14.3	1564	19500	3.8	105.0	47
1.750	14.4	1564	19450	6.2	102.0	75
1.500	14.4	1569	19470	10.5	98.0	121
1.250	14.6	1589	19460	20.3	94.0	225
1.125	14.7	1600	19460	27.9	89.0	293
1.000	14.7	1607	19470	37.7	82.0	363
0.875	14.7	1604	19460	50.3	73.0	428
0.750	14.5	1584	19450	63.6	60.0	447
0.625	13.9	1522	19440	77.7	46.0	420
0.500	13.0	1427	19450	91.5	32.0	343
0.375	12.0	1324	19440	103.9	19.0	233
0.250	10.9	1214	19420	116.6	9.0	123
0.000	10.0	1118	19420	131.4	0.0	0

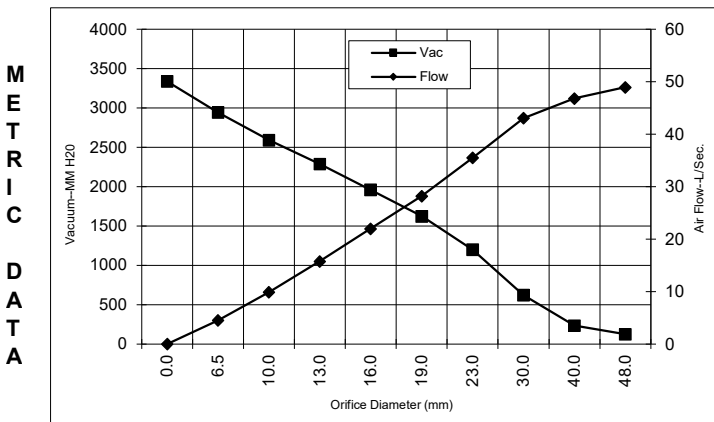

Orifice (mm)	Amps	Watts (In)	RPM	Vac (mm H ₂ O)	Flow (L/Sec)	Air Watts
48.0	14.3	1564	19478	123	48.9	59
40.0	14.4	1568	19464	234	46.8	107
30.0	14.7	1595	19460	622	43.1	262
23.0	14.7	1605	19463	1198	35.5	412
19.0	14.5	1583	19450	1623	28.2	446
16.0	13.9	1524	19440	1959	22.0	421
13.0	13.1	1437	19449	2289	15.8	351
10.0	12.2	1339	19442	2592	9.9	250
6.5	11.0	1220	19421	2946	4.5	129
0.0	10.0	1118	19420	3338	0.0	0

Note: Metric performance data is calculated from the ASTM data above.

* Data represents performance of a typical motor sampled from a large production quantity. Individual motor data may vary due to normal manufacturing variations.

Test Specs:	120 volts	Minimum Sealed Vacuum: 123	ORIFICE:	7/8"	Minimum Vacuum: 42	Maximum Watts:	1600
-------------	-----------	----------------------------	----------	------	--------------------	----------------	------

DIMENSIONS

NOTES:

- 1. LEADS: POWER; #16 GA., ONE BLACK, ONE WHITE.
GROUND; #18 GA., GREEN WITH YELLOW STRIPE.

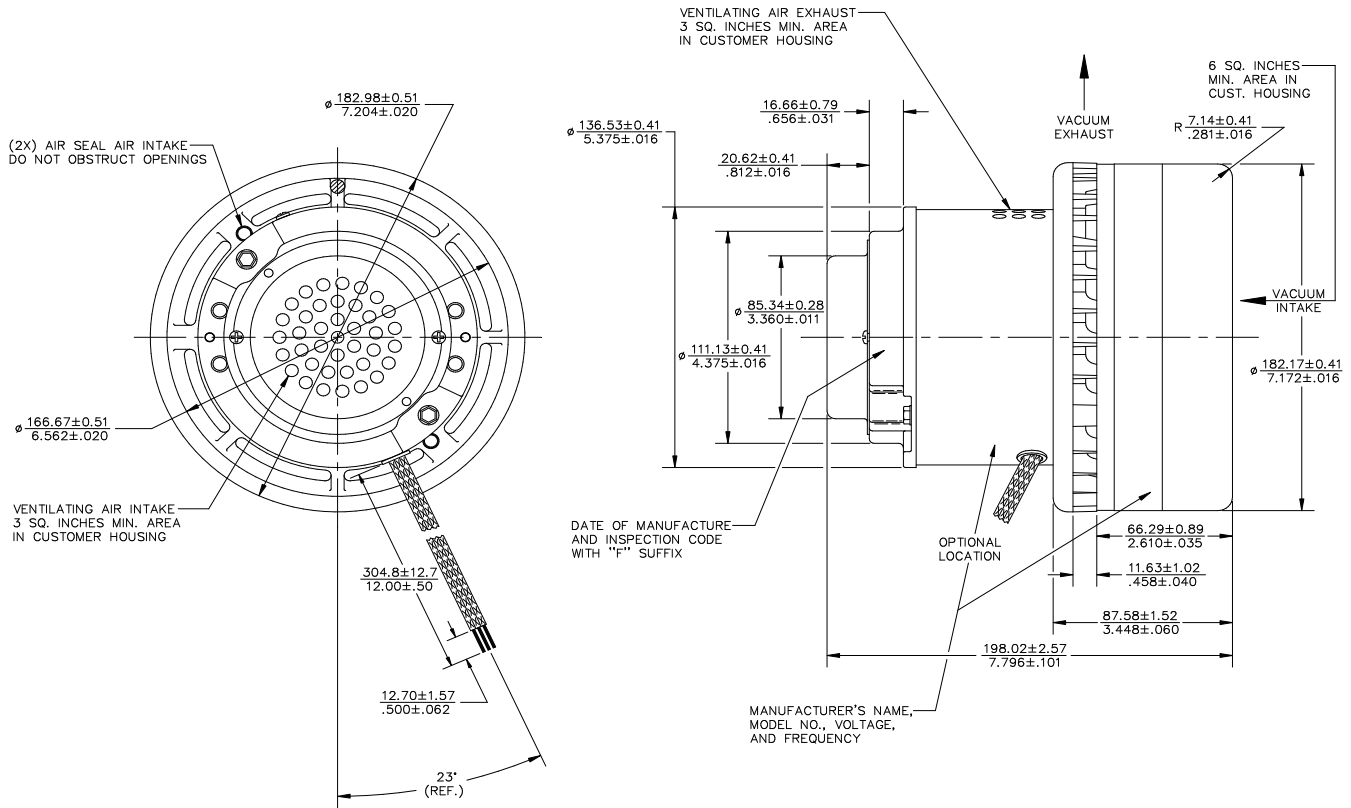

IMPORTANT NOTE: Pictorial and dimensional data are subject to change without notice. Contact factory for current revision levels.

WARNING - When using AMETEK Lamb Electric bypass motors in machines that come in contact with foam, liquid (including water), or other foreign substances, the machine must be designed and constructed to prevent those substances from reaching the fan system, motor housing, and electrical components. Lamb Electric vacuum motors other than hazardous duty models should not be applied in machines that come in contact with dry chemicals or other volatile materials. Failure to observe these precautions could cause flashing (depending on volatility) or electrical shock which could result in property damage and severe bodily injury, including death in extreme cases. All applications incorporating Lamb Electric motors should be submitted to appropriate organizations or agencies for testing specifically related to the safety of your equipment.

Bison, an AMETEK business.
 100 East Erie St. Suite 200
 Kent, OH USA 44240
BisonAMETEK.com