



DESCRIPTION

- One stage
- 120 volts
- 5.7"/145 mm diameter
- Ball/sleeve bearings
- Single speed
- Tangential bypass discharge
- Aluminum fan end bracket
- Aluminum commutator bracket

DESIGN APPLICATION

- Equipment operating in environments requiring separation of working air from motor ventilating air
- Designed to handle clean, dry, filtered air only

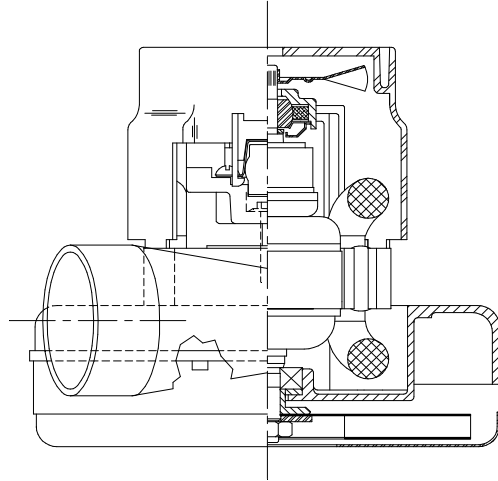

SPECIAL FEATURES

- Suitable for 120 volt AC operation, 50/60 Hz
- UL recognized, category PRGY2 (E47185)
- Skeleton-frame design
- Provision for grounding
- The Lamb Electric vacuum motor line offers a wide range of performance levels to meet design needs
- Same as 116520-50 except thermostat added to bottom coil. Protects against blocked cooling.

TYPICAL MOTOR PERFORMANCE.*

(At 120 volts, 60Hz, test data is corrected to standard conditions of 29.92 Hg, 68° F.)

ASTM DATA

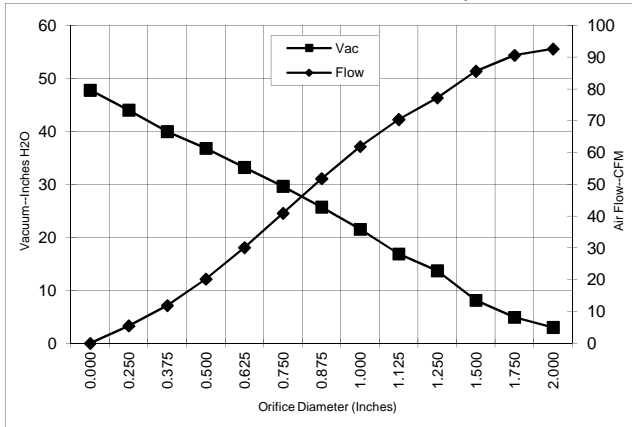

Orifice (Inches)	Amps	Watts (In)	RPM	Vac (In.H ₂ O)	Flow (CFM)	Air Watts
2.000	5.7	667	18550	3.0	92.6	32.7
1.750	5.7	671	18475	4.9	90.6	52.2
1.500	5.7	671	18400	8.1	85.6	81.5
1.250	5.7	670	18375	13.7	77.2	124.1
1.125	5.7	667	18400	16.9	70.4	143.2
1.000	5.6	655	19600	21.5	61.9	156.5
0.875	5.5	639	19050	25.7	51.8	156.5
0.750	5.2	613	19625	29.6	40.9	142.3
0.625	5.0	581	20175	33.2	30.1	117.2
0.500	4.7	552	21038	36.8	20.2	87.5
0.375	4.5	525	21725	40.0	11.9	55.7
0.250	4.3	506	22625	44.0	5.5	28.6
0.000	4.1	485	23175	47.8	0.0	0

METRIC DATA

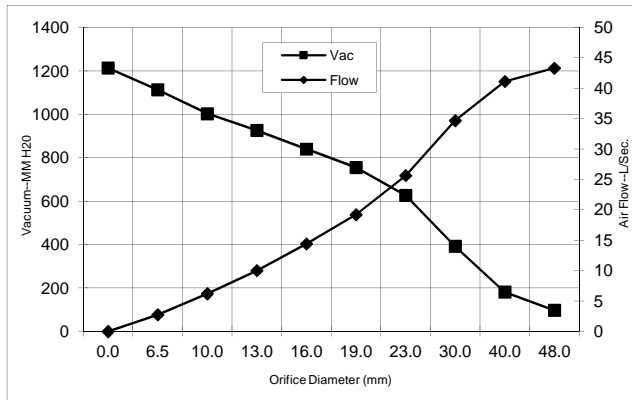

Orifice (mm)	Amps	Watts (In)	RPM	Vac (mm H ₂ O)	Flow (L/Sec)	Air Watts
48.0	5.7	669	18517	98	43.3	41
40.0	5.7	671	18423	182	41.1	73
30.0	5.7	668	18389	392	34.7	135
23.0	5.5	643	19188	626	25.6	157
19.0	5.2	612	19636	755	19.2	142
16.0	5.0	582	20153	840	14.4	118
13.0	4.7	555	20952	926	10.0	90
10.0	4.5	529	21622	1003	6.2	60
6.5	4.3	507	22580	1113	2.7	30
0.0	4.1	485	23175	1213	0.0	0

Note: Metric performance data is calculated from the ASTM data above.

* Data represents performance of a typical motor sampled from a large production quantity. Individual motor data may vary due to normal manufacturing variations.

Test Specs:	120 volts	Minimum Sealed Vacuum:	45.0"	ORIFICE:	7/8"	Minimum Vacuum:	25.0"	Maximum Watts:	800
--------------------	-----------	-------------------------------	-------	-----------------	------	------------------------	-------	-----------------------	-----

DIMENSIONS

NOTES:

1. LEADS: 18GA STRANDED, LEADS CAN BE ANY COLOR EXCEPT GREEN OR GREEN WITH YELLOW STRIPE.
2. GROUNDING OR EARTHING PROVISIONS: USE HOLES AS INDICATED FOR GROUNDING OR EARTHING. REFER TO APPROPRIATE LISTING OR REGULATORY AGENCY FOR PROPER METHOD OF GROUNDING OR EARTHING.

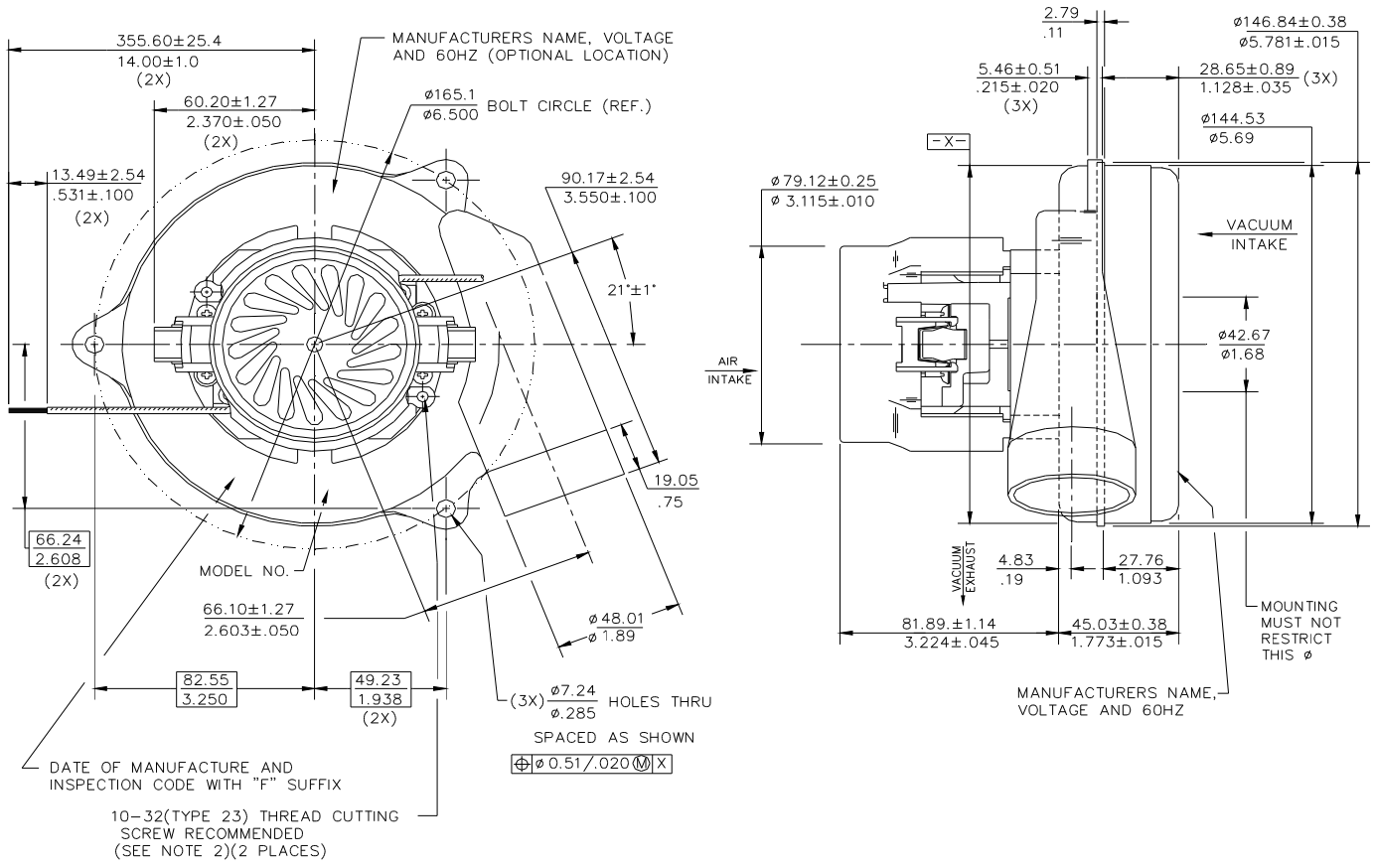

IMPORTANT NOTE: Pictorial and dimensional data are subject to change without notice. Contact factory for current revision levels.

WARNING - When using AMETEK Lamb Electric bypass motors in machines that come in contact with foam, liquid (including water), or other foreign substances, the machine must be designed and constructed to prevent those substances from reaching the fan system, motor housing, and electrical components. Lamb Electric vacuum motors other than hazardous duty models should not be applied in machines that come in contact with dry chemicals or other volatile materials. Failure to observe these precautions could cause flashing (depending on volatility) or electrical shock which could result in property damage and severe bodily injury, including death in extreme cases. All applications incorporating Lamb Electric motors should be submitted to appropriate organizations or agencies for testing specifically related to the safety of your equipment.

AMETEK/Floorcare & Specialty Motors
www.ametekfsm.com