



**AIR WATT™**  
S E R I E S

**DESCRIPTION**

- Dual-Tapered Fan System
- 120 Volts
- 5.7"/ 145 mm diameter
- Dual ball bearings
- Single speed
- Tangential bypass discharge
- Thermoset Plastic fan end bracket
- Thermoset Plastic commutator bracket

**DESIGN APPLICATION**

- Equipment operating in environments requiring separation of working air from motor ventilating air
- Designed to handle clean, dry, filtered air only

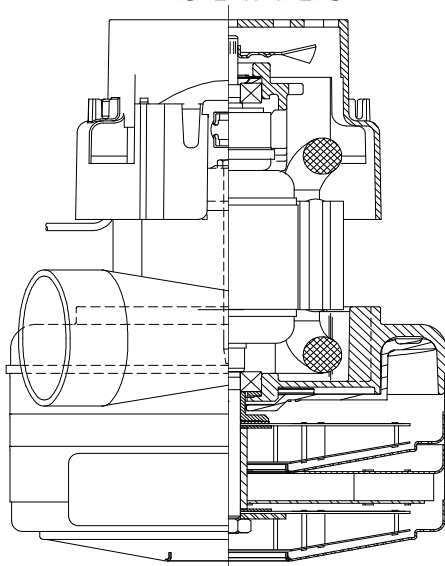

**SPECIAL FEATURES**

- Suitable for 120 Volts 50/60 Hz
- UL recognized, category PRGY2 (E47185)
- Provision for grounding
- Skeleton frame design
- Dual Tapered fan system
- The Lamb vacuum motor line offers a wide range of performance levels to meet design needs

**PEAK AIRWATTS**  
**584**  
Calculated in accordance with ASTM F2105

**TYPICAL MOTOR PERFORMANCE.\***

(At 120 Volts , 60Hz, test data is corrected to standard conditions of 29.92 Hg, 68° F.)

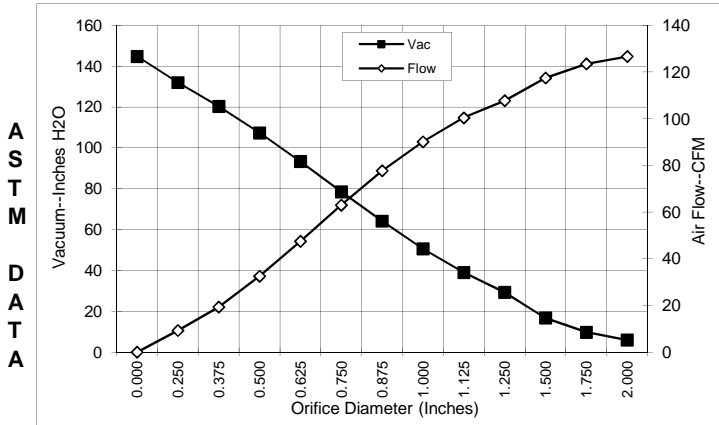

Orifice (Inches)	Amps	Watts (In)	RPM	Vac (In.H <sub>2</sub> O)	Flow (CFM)	Air Watts
2.000	15.8	1815	25077	6.0	126.7	89
1.750	15.8	1818	25080	9.8	123.5	142
1.500	15.8	1820	24943	16.8	117.5	232
1.250	15.8	1813	24940	29.3	107.8	371
1.125	15.7	1804	25070	39.0	100.4	460
1.000	15.5	1776	25073	50.6	90.1	537
0.875	15.1	1735	25457	64.2	77.8	587
0.750	14.5	1673	25933	78.5	63.0	582
0.625	13.7	1580	26630	93.4	47.5	522
0.500	12.5	1451	28060	107.4	32.6	411
0.375	11.3	1312	29360	120.4	19.3	274
0.250	10.1	1181	31207	132.0	9.3	144
0.000	9.2	1087	32630	144.8	0.0	0

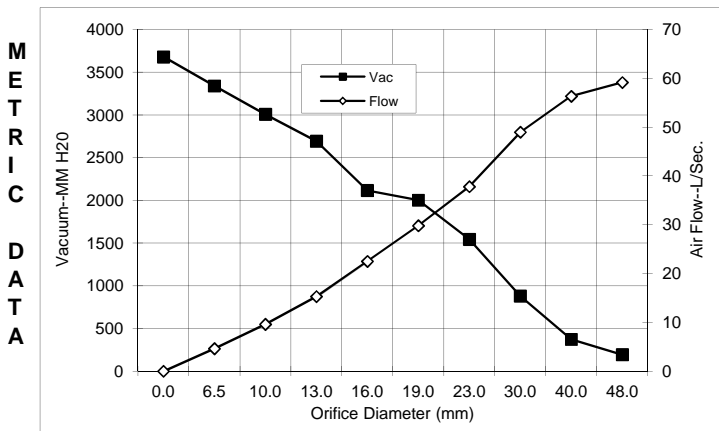

Orifice (mm)	Amps	Watts (In)	RPM	Vac (mm H <sub>2</sub> O)	Flow (L/Sec)	Air Watts
48.0	15.8	1816	25078	194	59.1	112
40.0	15.8	1820	24984	373	56.3	205
30.0	15.7	1808	25012	879	49.0	420
23.0	15.2	1745	25361	1544	37.8	515
19.0	14.5	1671	25947	2002	29.8	528
16.0	13.7	1584	26602	2115	22.5	470
13.0	12.6	1464	27917	2692	15.3	422
10.0	11.4	1333	29165	3007	9.6	294
6.5	10.1	1187	31114	3339	4.6	151
0.0	9.2	1087	32630	3679	0.0	0

Note: Metric performance data is calculated from the ASTM data above.

\* Data represents performance of a typical motor sampled from a large production quantity. Individual motor data may vary to normal manufacturing variations.

<b>Test Specs:</b>	120 volt	Minimum Sealed Vacuum: 76 134"	ORIFICE: 7/8"	Minimum Vacuum: 60"	Maximum Watts: 1850
--------------------	----------	--------------------------------	---------------	---------------------	---------------------

**DIMENSIONS**

**NOTES:**

1. POWER LEADS: 18GA STRANDED, LEADS CAN BE ANY COLOR EXCEPT GREEN OR GREEN WITH YELLOW STRIPE.
2. GROUND LEAD: 18GA STRANDED, GREEN OR GREEN WITH YELLOW STRIPE.
3. MOTOR IDENTIFICATION: MANUFACTURER'S NAME, MODEL NUMBER, VOLTAGE, FREQUENCY, INSPECTOR'S CODE WITH "FF" SUFFIX, DATE OF MANUFACTURE, AGENCY RECOGNITION CODE, PLANT LOCATION CODE, PATENT INFORMATION ONE OR MORE OF THE FOLLOWING PATENTS APPLY TO THIS MOTOR: 5482378; 5736805; 4669952; 4684835; 6561772, AND COUNTRY OF ORIGIN.
4. ALLOW [0.0016 SQ M]/2.6 SQ IN. MIN. FOR COOLING AIR INTAKE.
5. COOLING AIR INTAKE MUST BE SEPARATED FROM COOLING AIR EXHAUST.
6. VACUUM EXHAUST MUST BE SEPARATED FROM COOLING EXHAUST.
7. MOUNTING MUST NOT RESTRICT THIS DIAMETER.

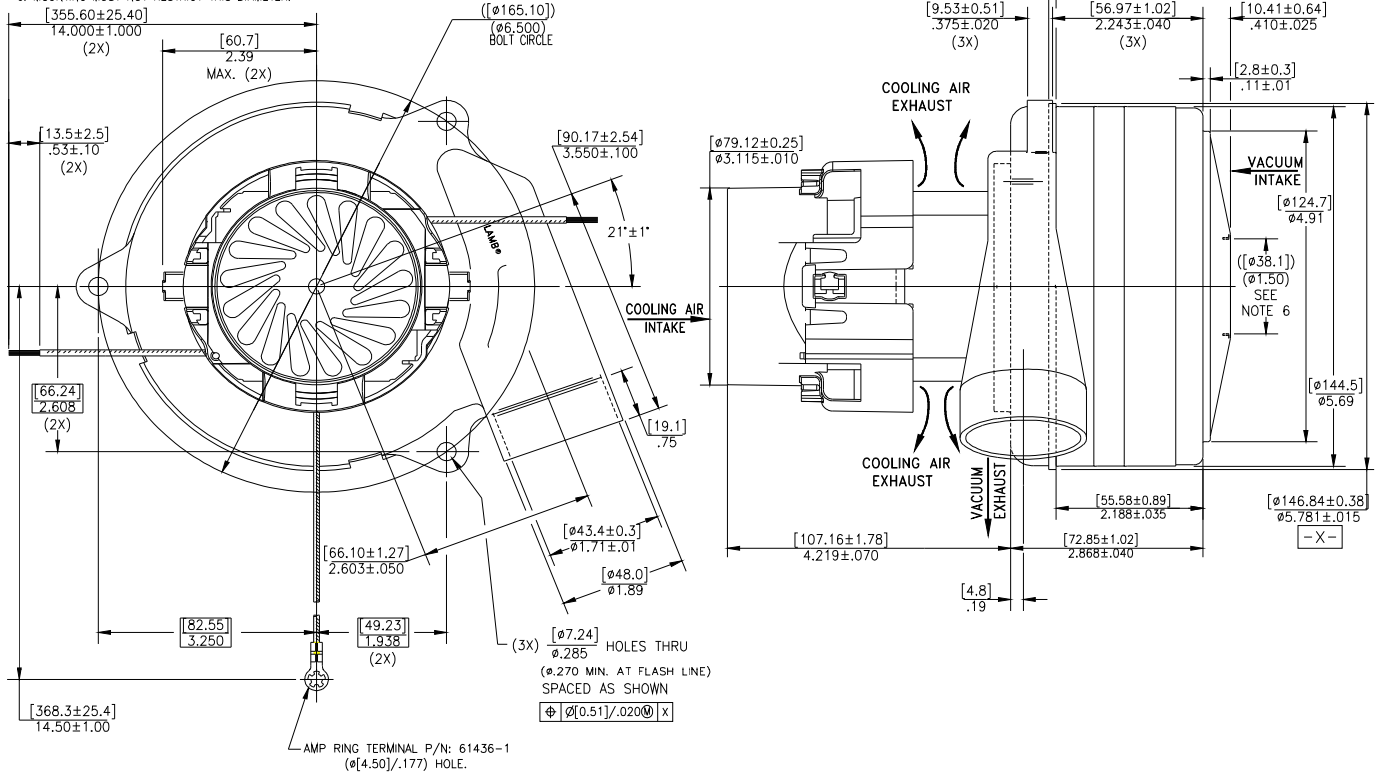

**IMPORTANT NOTE:** Pictorial and dimensional data are subject to change without notice. Contact factory for current revision levels.

**WARNING** - When using AMETEK/Lamb Electric bypass motors in machines that come in contact with foam, liquid (including water) of other foreign substances, the machine must be designed and constructed to prevent those substances from reaching the fan system, motor housing and electrical components. Lamb vacuum motors other than hazardous duty models should not be applied in machines that come in contact with dry chemicals or other volatile materials. Failure to observe these precautions could cause flashing (depending on volatility) or electrical shock which could result in property damage and severe bodily injury, including death in extreme cases. All applications incorporating Lamb motors should be submitted to appropriate organizations or agencies for testing specifically related to the safety of your equipment.

**AMETEK/Floorcare & Specialty Motors**  
[www.ametekfsm.com](http://www.ametekfsm.com)